

SF5000. 3/8

"F" FLEXIBLE Series
Solenoid / Pneumatic Valves

- 5/2, 5/3, 3/2 - 3/8
- 32mm Body Width
- Transition Flow 2000ℓ/min (5bar)

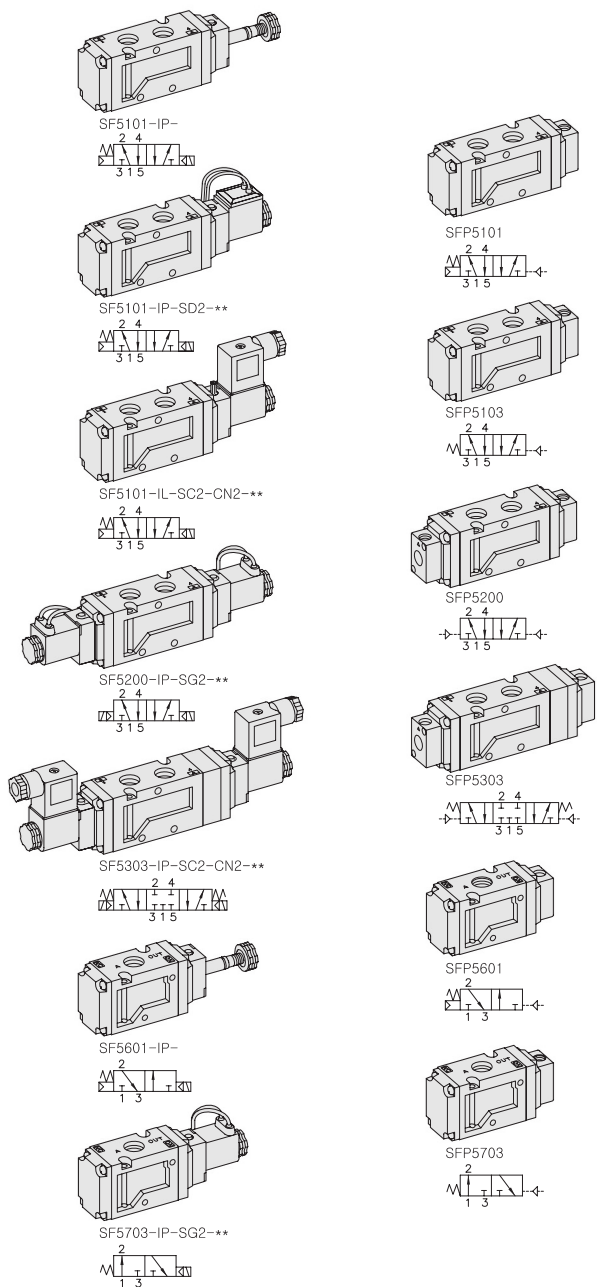

***: Voltage Selection (see page 80)

SPECIFICATION

ITEM	SERIES	SOLENOID, PNEUMATIC	
		FUNCTION	
		5, 3 Port 2 Position	5 Port 3 Position
Fluids		Compressed Air & Inert Gases	
Pressure(bar)		1.5~10.0	2.0~10.0
Eff. Section Area(mm ²)-5bar		36.0	30.0
Ambient & Fluid Temp.		5~60°C (41~140°F)	
Response Time(5bar)		30ms or Less	40ms or Less
Max. Working Frequency		5c/sec	3c/sec
Lubrication		Not Required(Use ISO VG32 #)	
Manual Override		Push Button(Standard), Lever Lock(Option)	
Coil Insulation Class		F-Class or Equivalent	
Permissible Voltage Variation		±10% of Rated Voltage	
Off Min. Residual Voltage		AC:20% or Less / DC:10% or Less	
Power Consumption		Holding-AC:5.5VA(60Hz) / DC:2.5W	

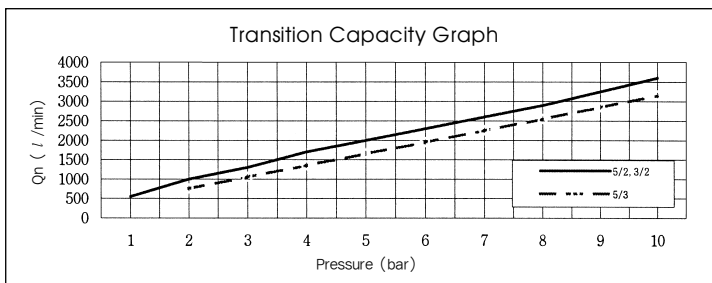

The Material of Parts

- Valve Body : Die-Cast Aluminium
- Spool : Aluminium
- Seals : NBR
- Spring : Stainless
- Cap : Zinc Pressure Die-Cast
- Pilot Parts : Glass Filled Nylon
- Armature : Stainless Steel
- Armature Seals : Viton

* The specification on each item can be amended without any prenotice to improve a performance.
* The specification on each item can be different from actual specification.

ORDERING NO.

SF5 1 0 1 - I P - SC2 - CN2 - A2

Valve Series	Function	Port Size & Thread	Return Method	Int/Ext. Pilot	Manual Operator	Solenoid Coil Type	Connector Type	Voltage
SF5 : Solenoid Valve	1 5/2 Single	0 G 3/8	0 None	1 Internal Pilot	0 None	0 None	0 None	0 None
	2 5/2 Double	1 NPT 3/8	1 Air + Spring		P Push Non-Locking	SC2 3 Pin Connector Coil	CN2 Normal Connector	A2 AC 220V
	3 5/3 Closed Center		2 Air		L Lever Locking	SG2 Grommet/Flying Leads	CD2 Connector With LED	A1 AC 110V
	4 5/3 Open Center		3 Spring			SD2 Grommet/Flying Leads With LED	CZ2 Connector With LED & Surge Suppressor	A4 AC 24V D4 DC 24V D2 DC 12V
SFP5 : Pneumatic Valve	5 5/3 Pressure Center							
	6 3/2 Normally Closed							
	7 3/2 Normally Open							